

5年生男子( -45kg )

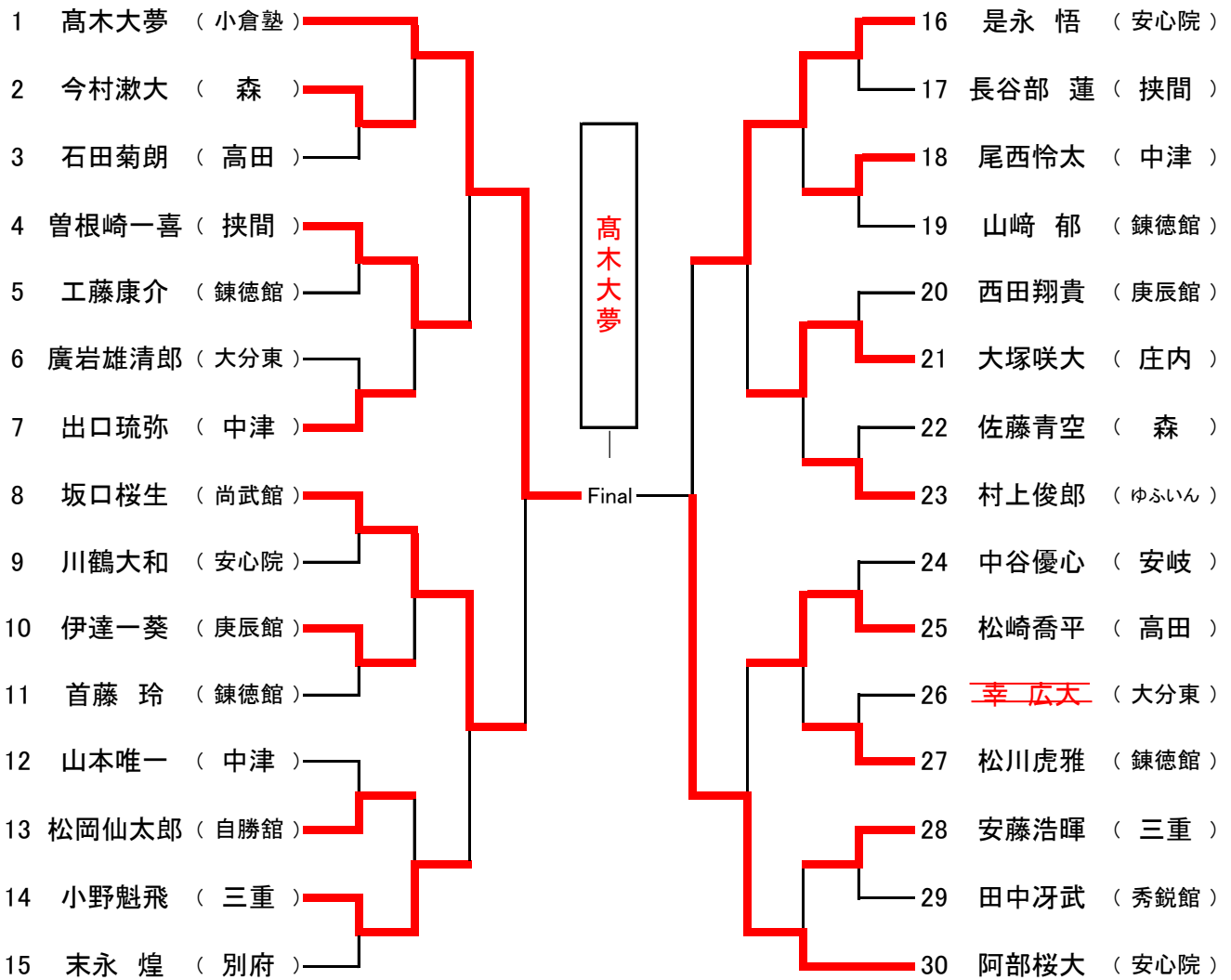

5年生男子(+45kg)

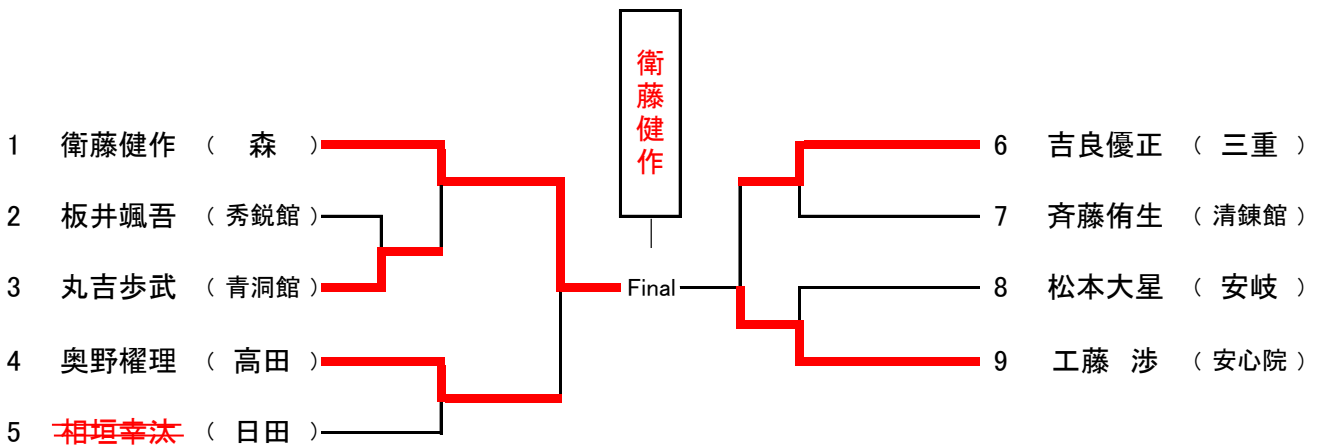

6年生男子( -50kg )

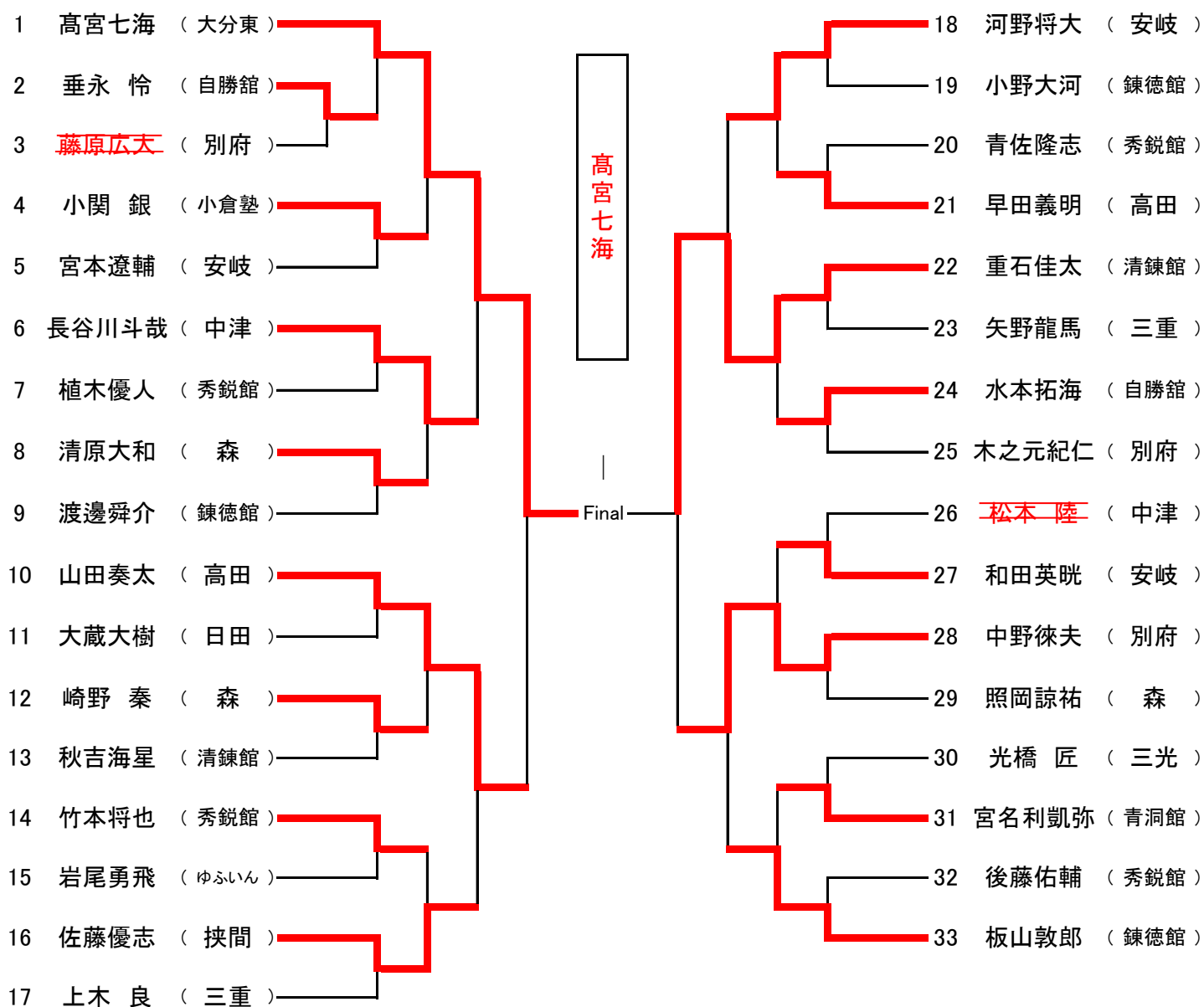

6年生男子(+50kg)

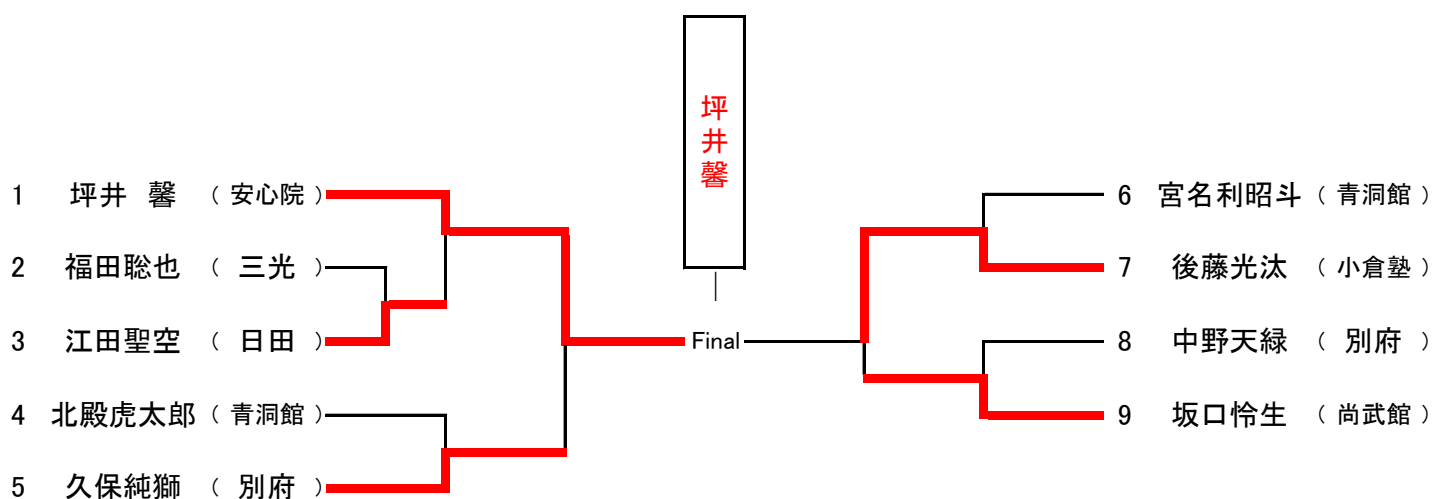

5年生女子(-40kg)

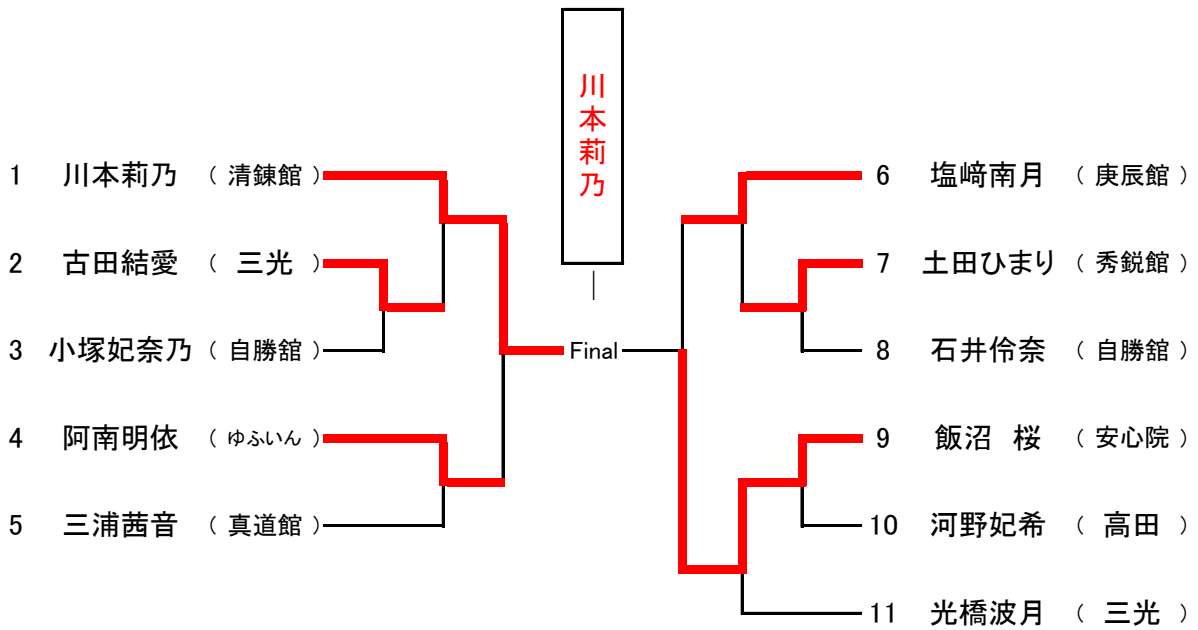

5年生女子(+40kg)

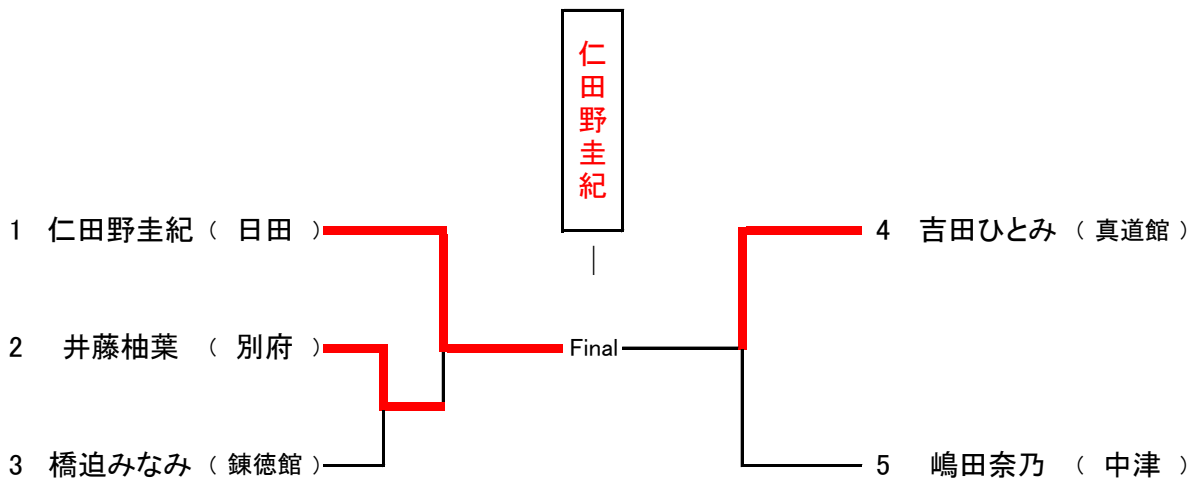

6年生女子(-45kg)

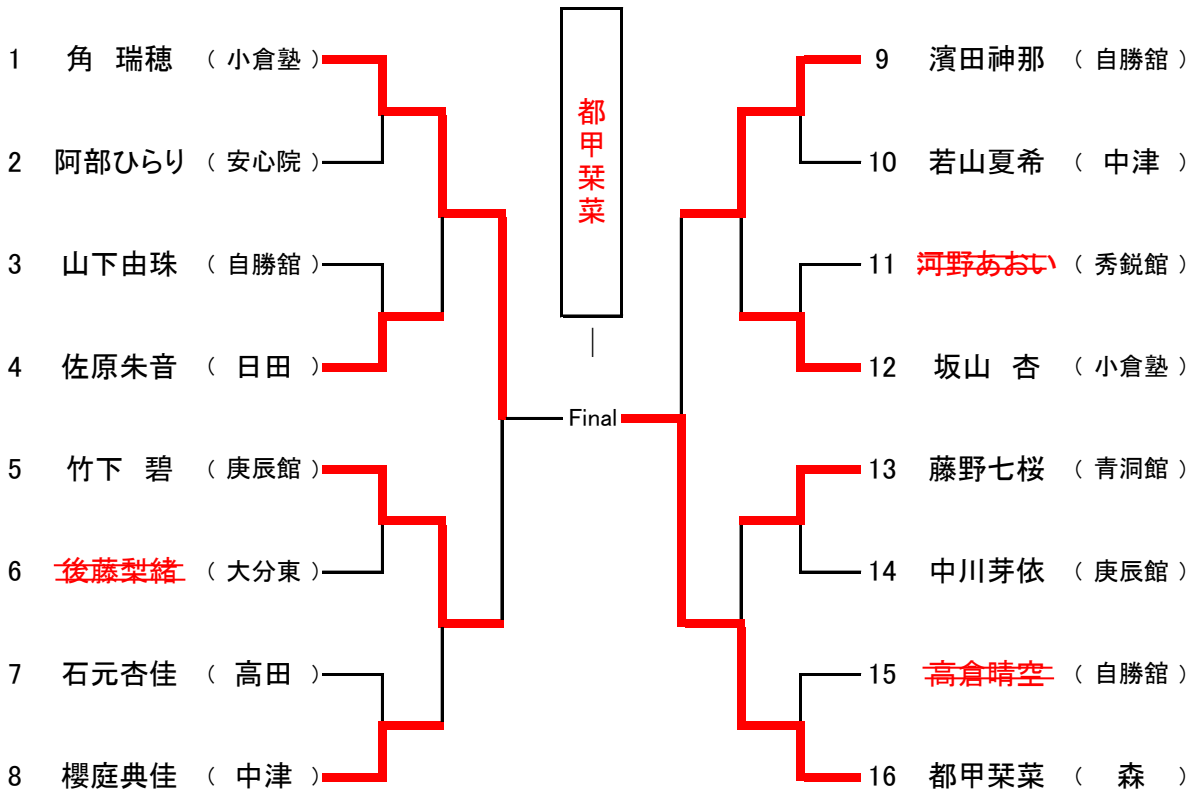

6年生女子(+45kg)

